

Electric drain valve w/ float and pilot valve



<p><u>Outlet Ø</u></p> <p>-</p>	<p><u>Removal capacity (gal/h)</u></p> <p>-</p>	<p><u>Operating pressure (psi)</u></p> <p>-</p>	<p><u>Protection rating</u></p> <p>-</p>
<p><u>Supply voltage (V)</u></p> <p>-</p>	<p><u>Temperature</u></p> <p>-</p>	<p><u>Description</u></p> <p>Repair kit for PDE 100 automatic drain</p>	<p><u>Operating pressure</u></p> <p>0 to 232 psi</p>
<p><u>ID Passage</u></p> <p>5/32"</p>	<p><u>Temperature</u></p> <p>+35°F to +131°F</p>	<p><u>Drain cycle</u></p> <p>0,5 - 45 min</p>	<p><u>Drain opening</u></p> <p>0,5 - 10 sec</p>
<p><u>Supply voltage</u></p> <p>24 - 220 V 50/60 HZ</p>			

Description

Reference	Outlet Ø	Removal capacity (gal/h)	Operating pressure (psi)	Protection rating	Supply voltage (V)	Temperature	Description
PDE 100KR	-	-	-	-	-	-	Repair kit for PDE 100 automatic drain

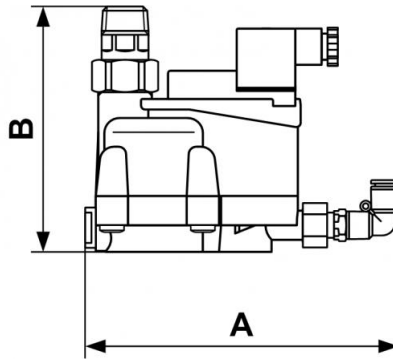

Dimensions

Reference

PDE 100KR